

Annual Environmental Report

2016 Edition



The Akita Plant



NLT Technologies, Ltd.

Table of Contents

Subject	Page
Message from the President	3
Company Overview	4
Map of NLT Technologies Business Sites	5
Main Products	6
Environmental Policy	7
Environmental Management Organizational Structure	8
Environmental Management System	9
2015 Results	10
Environmentally Friendly Products	11
Chemical Substances Contained in Products System	12
Environmental Impact Mass Balance	15
Preventing Global Warming (Promoting Energy Conservation)	16
Controlling Chemical Substances	17
Waste Control	18
Legal Compliance	19
Risk Management	20
2016 Targets	21

Message from the President

Based on a keen awareness of our natural environment, NLT Technologies strives to achieve earth-friendly production methods.

Having set the goal of becoming the premier supplier of industrial display solutions globally, we will continue strengthening our customer focus and maintain a strong commitment to innovation and a willingness to take on new challenges in order to maintain our technical advantage, as we deepen our alliances with our parent company Tianma Micro-Electronics Group and other members of its group of companies.

We proactively and consistently address environmental issues as a cornerstone of our corporate social responsibility (CSR) activities. In 2015, as part of environmental initiatives in the sphere of product development, we developed SFT2 for commercialization, a technology that helps reduce display power consumption by significantly increasing aperture ratios. We also eliminated all use of mercury from our backlights and reduced product power consumption by completely replacing the cold cathode fluorescent lamps (CCFLs) formerly used in product backlights with LEDs. We are making progress in the following areas under the company slogan, to achieve earth-friendly production methods, based on an awareness of nature. These efforts are based on a keen awareness of the impact company activities have on the natural environment.

- Contributing to the development of an energy-conserving society by developing applications for LCD displays with low environmental impact, such as low energy consumption and light weight.
- Creating environmentally sensitive products in various ways, including green procurement and compliance with RoHS directives.
- Continuing initiatives to reduce the environmental impact of manufacturing activities at our plants.

We intend to continue contributing to the development of a sustainable society by appropriately directing the knowledge and experience of all our employees. We welcome frank comments and opinions from our stakeholders to help guide our future actions in the area of environmental management.



Deshu Yu, President
NLT Technologies, Ltd.

Company Overview

Name: NLT Technologies, Ltd.

Address: 1753 Shimonumabe, Nakahara-Ku, Kawasaki, Kanagawa, Japan

Established: April 1, 2003

President: Deshu Yu

Capital: 4.3 billion yen

Lines of business: Research, development, design, manufacture, sale, and maintenance of color / monochrome display modules and related electronic devices

Number of employees: Approximately 600

[History]

Mar. 1989	Color LCD Development Promotion Headquarters established.
Apr. 1992	Color LCD Division established
Nov. 1993	Acquired ISO 9002 certification
Feb. 1994	Acquired ISO 9001 certification
Jul. 1997	Acquired ISO 14001 certification
Apr. 2003	NEC LCD Technologies, Ltd. established as independent company
Apr. 2007	NEC Akita and NEC Kagoshima were merged into NEC LCD Technologies
Dec. 2009	Production consolidated at Akita Plant
Jul. 2011	Under the joint venture with Shenzhen AVIC OPTOELECTRONICS, LTD., the company name has changed to NLT Technologies, Ltd.
Aug. 2014	Acquired ISO/TS 16949 certification

Map of NLT Technologies Business Sites

NLT Technologies sells products researched and developed at the Head Office and produced at the Akita Plant. It produces TFT LCD displays in a wide range of sizes, based on intended applications, from two sizes of glass substrates.

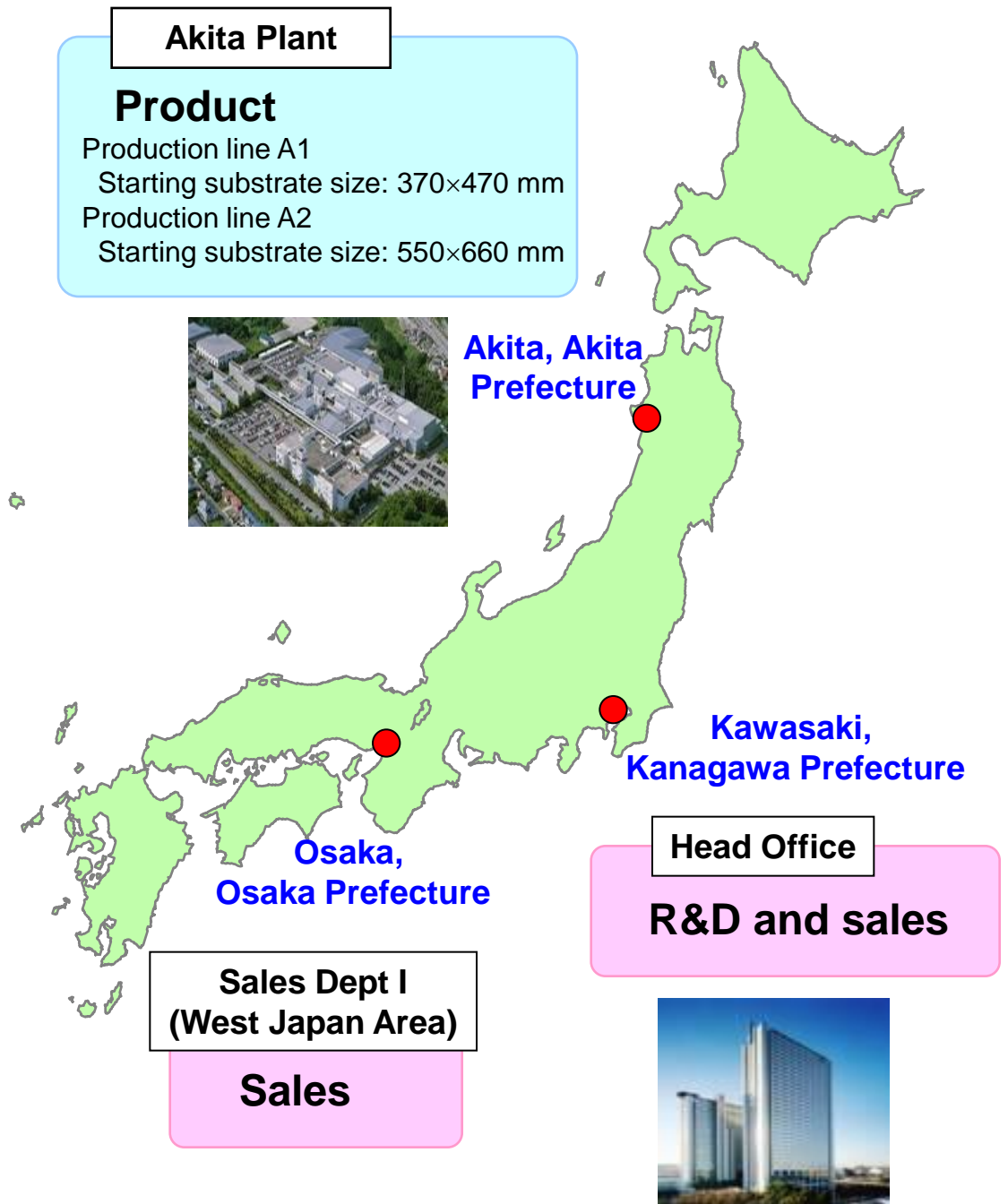

Main Products

Shown below are some of the main products. These products are characterized by energy-conserving performance achieved through low power consumption.



<Monitors>

These are used as monitor panels in high-end and professional fields: for example, as high-definition monitors for the medical and graphics applications.



<Industrial use>

These are used across a wide range of fields, including panel computers and measurement equipment and broadcasting.

Environmental Policy

One of our goals as a global corporation is to help achieve a sustainable society. We are actively engaged in global environmental preservation activities in the development of our display products and production technologies. Key objectives of our environmental policy are:

1. Make continual improvements to NLT Technologies' environmental management system to enhance our environmental performance.
2. Reduce the environmental impact associated with our products and manufacturing processes as far upstream as possible to prevent pollution and protect the environment.
 - i Throughout a product's life cycles, from material procurement to disposal, NLT Technologies strives to save energy and purchase green whenever possible to provide green products, and minimize the environmental impact of our products and technologies.
 - ii Endeavor to reduce the environmental impact in our manufacturing processes using measures such as energy and resource conservation and waste reduction.
3. Comply with applicable legal requirements and with other requirements to which NLT Technologies subscribes related to its environmental aspects.

Established: April 1, 2016
Deshu Yu, President
NLT Technologies, Ltd.

Environmental Management Organizational Structure

We established the environmental management organization outlined below to advance activities in accordance with our environmental management system (EMS). The President appoints the Corporate EMS Representative, Deputy Representative, District EMS Representatives, Corporate EMS Secretariat, Chief Auditors and others. The District EMS Representatives make decisions and appointments related to the organization of these structures within their districts, establishing clear roles and responsibilities of each position through in-house rules.

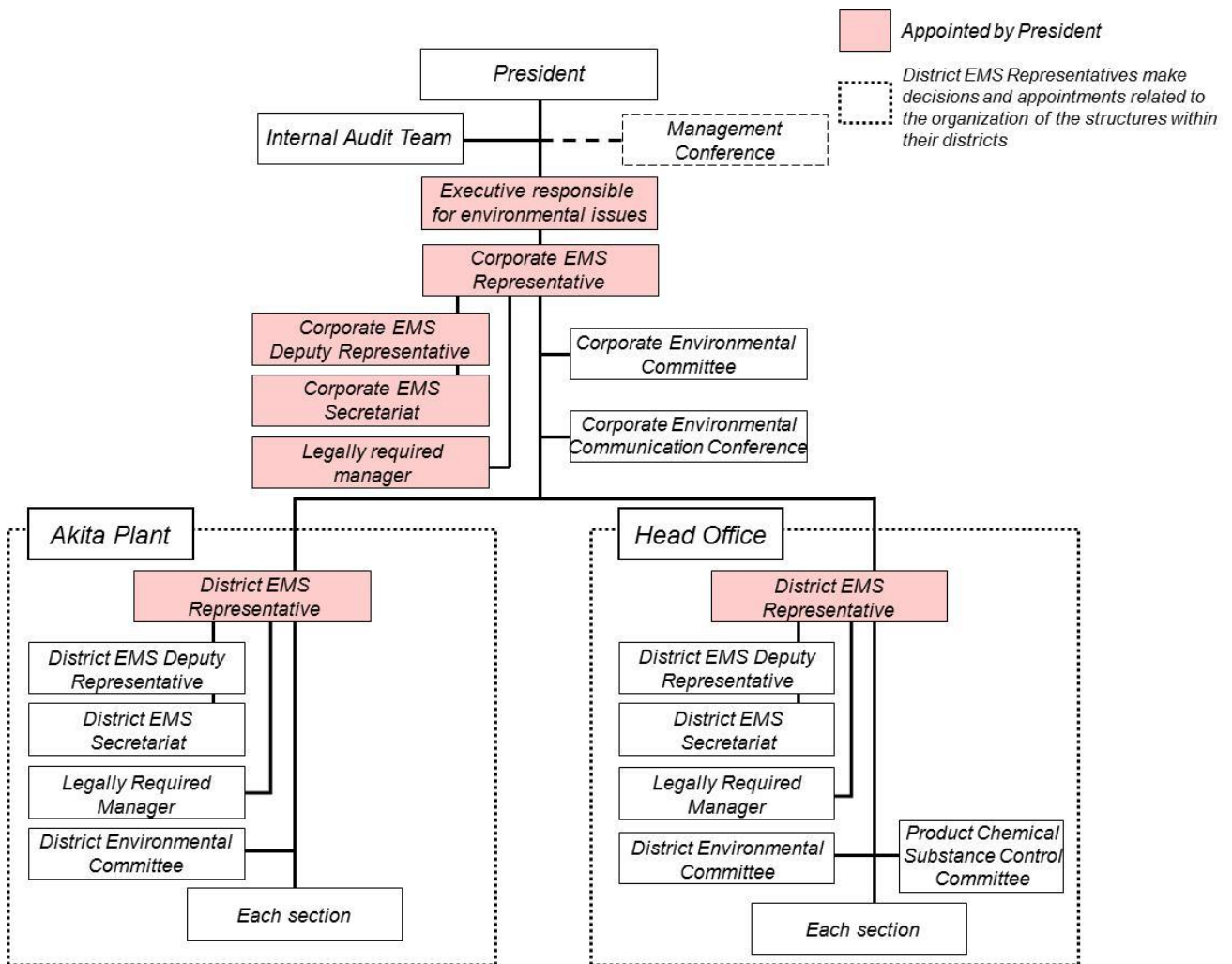

2015 Results

Summarized below are the results of CY 2015 initiatives. 2016 initiatives will be based on these results.

◆Assessment◆ ○: Achieved △: Achieved at rate of 80% or higher ×: Achieved at rate of under 80%

Items	Targets	Results	Assessment
Promoting new supplier assessment	100%	100%	○
Maintaining a 100% green procurement rate	100%	100%	○
Maintaining 100% compliance with RoHS	100%	100%	○
Promoting paperless of specifications	60% or more	98.3%	○
Reduction in energy-derived CO ₂ emissions	736.7 kg-CO ₂ /m ² or less	809.4 kg-CO ₂ /m ²	△
Reduction of chemical substances	38.6 kg/m ² or less	39.9 kg/m ²	△
Reduction in waste emissions	17.7 kg/m ² or less	17.5 kg/m ²	○

Environmentally Friendly Products

■ NEW 4K2K LCD WITH THE PROPRIETARY SFT2 TECHNOLOGY FOR ULTRA-HIGH TRANSMISSIVITY



NLT Technologies, Ltd. has developed a new 19.5” diagonal 4K2K resolution LCD with a proprietary pixel structure that delivers high transmissivity and high-density color display.

The new LCD utilizes NLT’s proprietary new Super Fine TFT2 (SFT2) technology, which is comparable to In-Plane Switching (IPS) and an evolutionary version of NLT’s proprietary wide viewing angle technology, Super Fine TFT. NLT has attained an ultra-high aperture ratio to achieve transmissivity levels 180% higher than those of conventional technology even at high density LCD panels.

(1) Low power consumption

By improving the panel's light-utilization efficiency, high luminance is achieved while keeping power consumption low. Combined with an optimal backlight design, this enables power consumption to be reduced, delivering a power savings of approximately 35% compared with existing displays.

(2) Reduction of heat generation

Because the amount of power consumed by the backlight is dramatically reduced, the amount of heat generated by the LCD module is also reduced.

(3) Wide color gamut

NLT's proprietary new SFT2 technology combines outstanding viewing angle characteristics with high transmissivity. A wide color gamut (NTSC ratio in excess of 80%) is achieved without sacrificing luminance.

◆ Figure: Comparison of aperture ratio

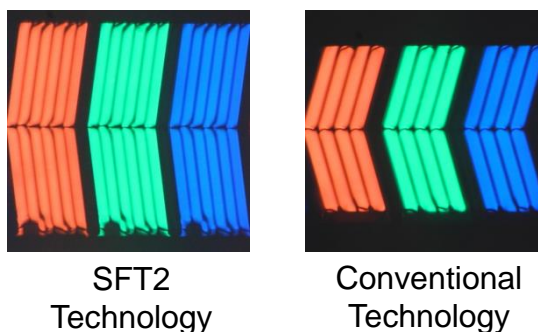

Chemical Substances Contained in Products System (1)

■ Green Procurement

We do our part to further green procurement, in this way helping to establish a recycling society. We do this by expanding markets for green products, promoting the development of environmentally sensitive products, and raising awareness among designers and developers. Green procurement prioritizes the purchase of materials with low environmental impact. We have established green-procurement requirements for parts and materials and a green certification program for suppliers who meet these requirements. Since 2005, we have maintained a green procurement rate of 100%. In 2015, we continue to make 100% of our purchases from green certified suppliers.

Essential Condition for Green Procurement of Parts and Materials

Category	Items to Be Checked
Approach Environmental management	Establishment of environmental management system
	Non-use of substances banned from manufacturing Process
	Establishment of system for examination of chemical Substance content
Products	Non-use of substances banned from products

■ Restrictions on the Purchase of Substances Prohibited from Use in Products

In addition to green procurement, we provided a list of environmental substances restricted by NLT Technologies. These restrictions also include chemical substances prohibited by specific customers and other individually designated chemical substances. Copies of these restrictions are distributed to suppliers of parts and materials under the title *Common Specification of Green Procurement*. We ask suppliers to assess the chemical substances found in parts and materials delivered to us, based on design diagrams and the *Common Specification of Green Procurement*. The data collected in this way is registered into an internal database and shared for use in selecting parts and materials at the design stage, as well as for product assessment. Procurement restrictions also apply to chemical substances occurring in shipping and packaging materials, for which similar surveying, data registration, and materials selection are conducted.

Chemical Substances Contained in Products System (2)

■ Our products are RoHS compliant

The European Union (EU) issued a RoHS Directive,^{*1} taking effect from July 1, 2006, that restricts the use of certain hazardous substances. As a result, electrical and electronic equipment containing any of the six target substances (lead, mercury, cadmium, hexavalent chromium, PBB^{*2} and PBDE^{*3}) is restricted from the EU market.

Out of concern for the environment, NLT Technologies began reducing the use of hazardous substances in our LCD modules prior to the RoHS directive. We have eliminated the six substances targeted in the RoHS directives as well as other substances we have identified as potentially hazardous, so that our products are now RoHS compliant.

The RoHS Directive underwent major revisions in July 2011. The updated RoHS Directive (RoHS II) went into effect in January 2013.

In June 2015, the *Official Journal of the European Union* also announced that the number of restricted substances would grow from six to ten substances and that the addition of restrictions on four phthalates^{*4} would enter into effect on July 22, 2019.^{*5} We remain committed to meeting all RoHS II requirements, including restrictions on phthalic acids.

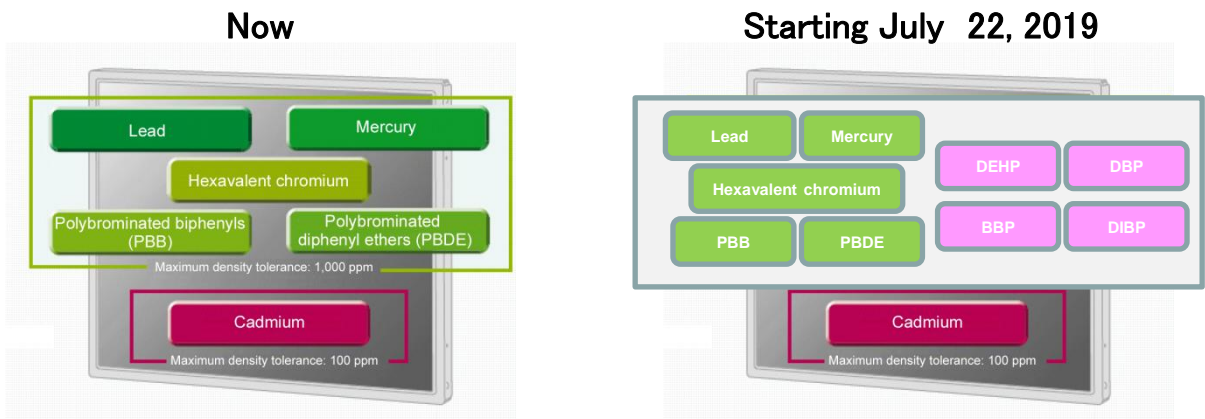

*1 RoHS: The Restriction Of The Use Of Certain Hazardous Substances In Electrical And Electronic Equipment

*2 PBB: Poly brominated biphenyl

*3 PBDE: Poly brominated diphenyl ether

*4 Four phthalates

DEHP: Bis(2-ethylhexyl)phthalate

DBP: Dibutyl phthalate

BBP: Butyl benzyl phthalate

DIBP: Diisobutyl phthalate

*5 The restriction shall not apply to monitoring and control instruments placed on the market before 22 July 2021.

Chemical Substances Contained in Products System (3)

■ Compliance with chemical substances restriction (REACH regulations)

In place from June 1, 2007, the EU REACH*¹ regulations require the registration, evaluation, and authorization of all chemical substances entering the EU, based on factors such as volumes imported or produced.

For molded products containing substances of very high concern (SVHC*²) and SVHC candidates in concentrations of 0.1% or more, a system must be in place throughout the supply chain to communicate information such as substance names, volumes included, and information enabling safe use.

To comply with REACH regulations, we are currently developing a management system that incorporates BOM*³ management of the parts and materials used in products, surveys of the chemical ingredients used therein, and processing of the data collected.

*1 REACH: Registration, Evaluation, Authorization and Restriction of Chemicals

*2 SVHC: Substances of Very High Concern

*3 BOM: Bill of Materials

■ Joint Efforts with Suppliers

As required by various measures such as the European Union's RoHS directive, specifically designated harmful chemical substances occurring in products must be controlled. Each company in the supply chain must implement efforts to ensure proper control of the chemical substances found in various products.

As part of these efforts, we have developed an evaluation tool that promotes the proactive control of chemical substances occurring in products among the suppliers themselves. To ensure PMR*⁴ assessments, we distribute supplier assessment check forms to our suppliers. These forms are used to control various chemical substances occurring in products. Alongside spot inspections by NLT Technologies, such efforts improve supplier control systems by enabling supplier self-assessments.

*4 PMR: Process Management Review

Environmental Impact Mass Balance

The diagram below shows the resource volumes used in and the wastewater, carbon dioxide, and waste generated at the Akita Plant in CY 2015. In 2016, we will continue to strive to promote effective resource use; to promote energy conservation initiatives; and to reduce resource use and emissions still further.

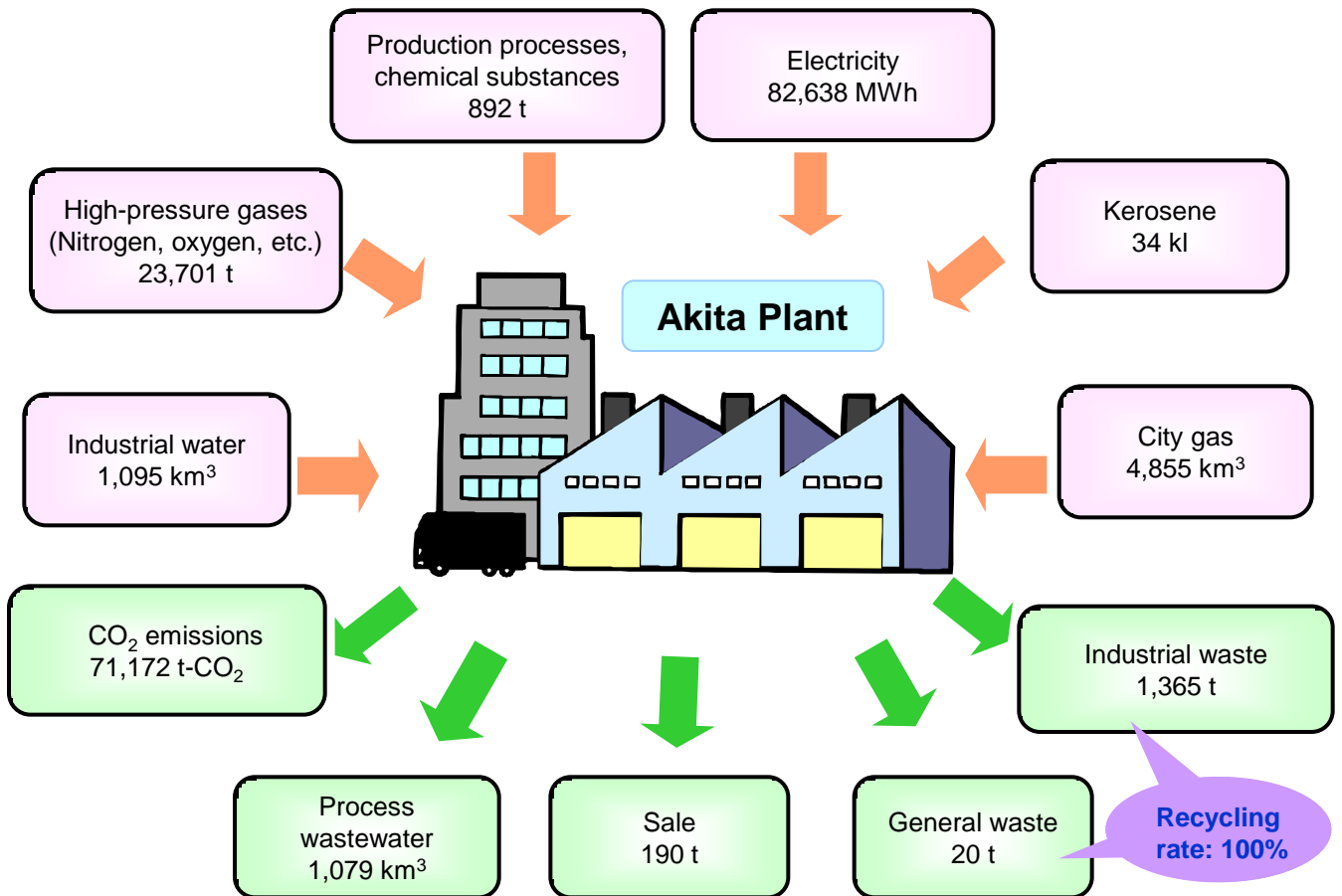

Preventing Global Warming (Promoting Energy Conservation)

Recognizing global warming as an important environmental issue, we promote a wide range of efforts to reduce carbon-dioxide emissions, including reductions in energy used by plants, turning off lights when not needed, and using air-conditioning system in energy conservation mode at our offices.

◆Pure-water humidification system adopted◆ (from January 2009)



Previously, we used steam in air handling units to maintain humidity levels inside clean rooms. We are now switching to pure-water spray humidification to cut the fuel and electricity needed to produce steam.

← Pure water sprayed from spray nozzles

◆Factory wastewater waste heat recovery system adopted◆ (from January 2014)

Production lines at the Akita Plant use pure water at temperatures of roughly 23° C, generated using industrial water as the source water.

Since the temperature of the industrial water can fall to as low as roughly 4° C in the coldest months of the year, the plant previously used steam to heat the water to temperatures suitable for use on production lines. Adoption of this system, which heats the industrial water by running the waste heat from factory wastewater (roughly 20° C year round) through a heat exchanger, has made it possible to reduce the amount of steam used, reducing the volume of city gas used to produce steam.

◆Free-cooling system adopted◆ (from January 2014)

Taking advantage of Akita's northern climate, this system conserves electricity for producing cold water for air-conditioning use. This is done by passing water cooled in a cooling tower by outdoor air through a heat exchanger (or a refrigeration unit in summer and between seasons).

(This is an application of a similar system first adopted in 2010.)

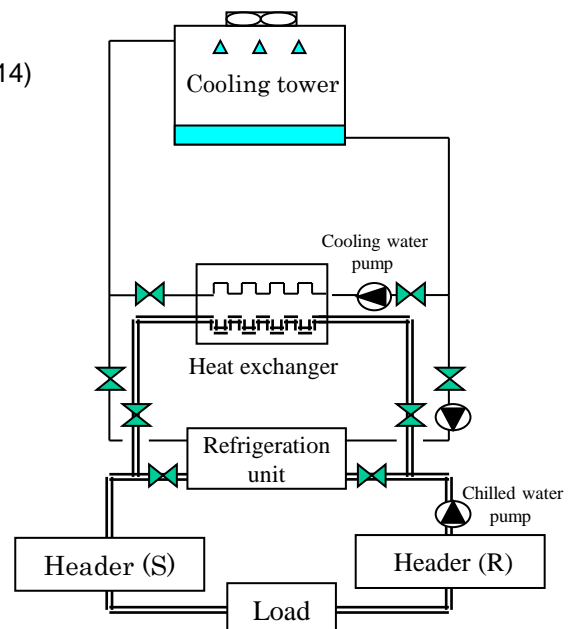

Controlling Chemical Substances

Various chemical substances are used in processes related to manufacturing and processing wastewater and exhaust gas emitted from manufacturing processes. For purposes of monitoring environmental impact and control over handling safety, we maintain a control structure of chemical substances, reduce the volumes of materials used, and promote the transition to substances with lower levels of toxicity and environmental impact.

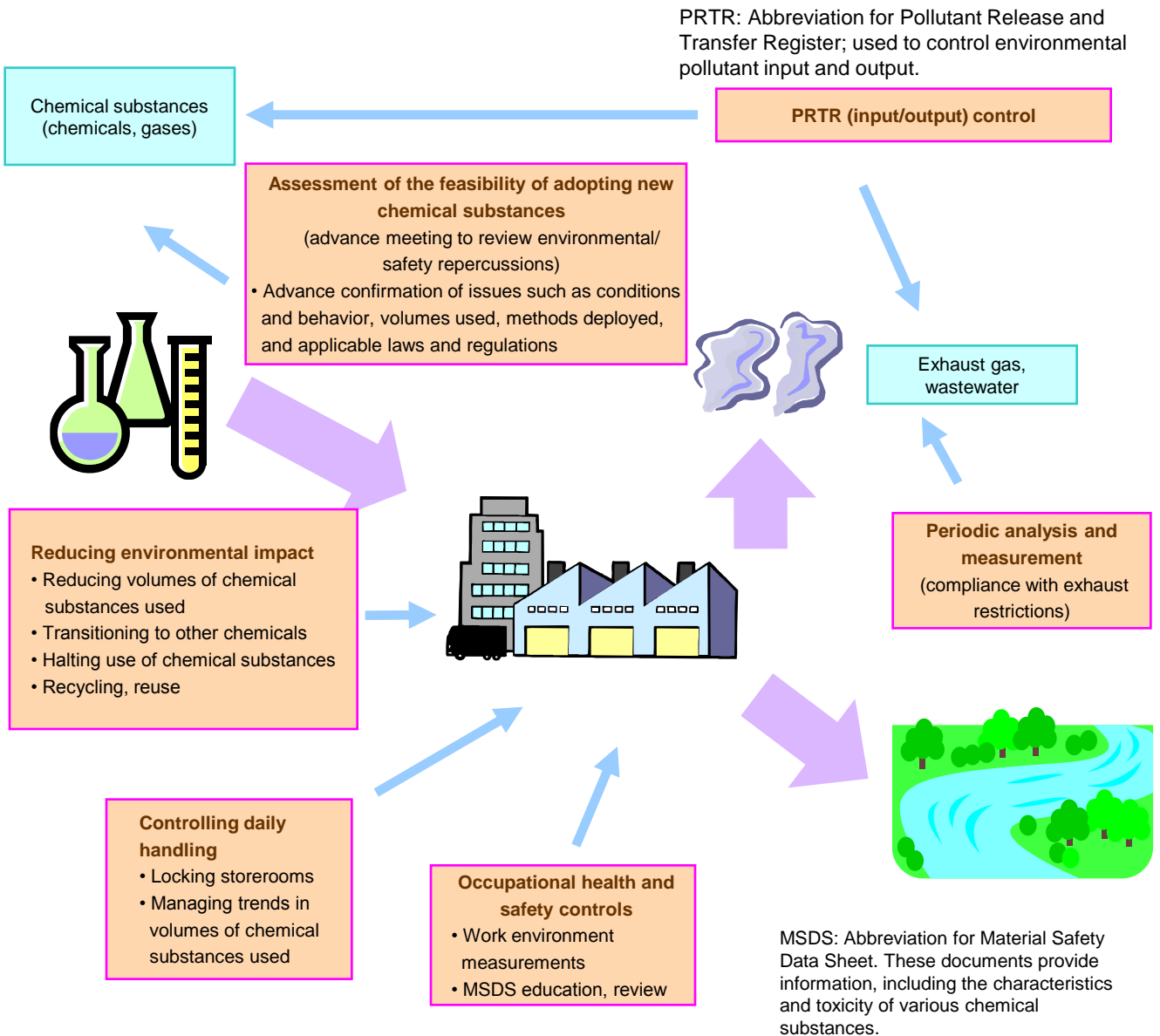

Waste Control

The Akita Plant continues to recycle all generated waste and to implement zero-emissions efforts through waste segregation and the “three Rs” (reduce, reuse, recycle). To ensure all waste is disposed of properly, waste processing is contracted out to licensed, specialized waste processing firms. Final processing is confirmed using manifests. In addition, waste-processing facilities are periodically subjected to on-site inspections.

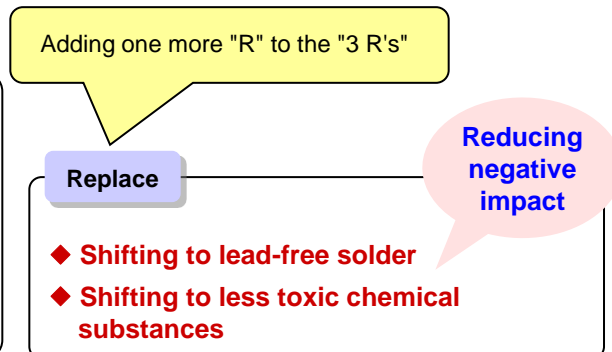
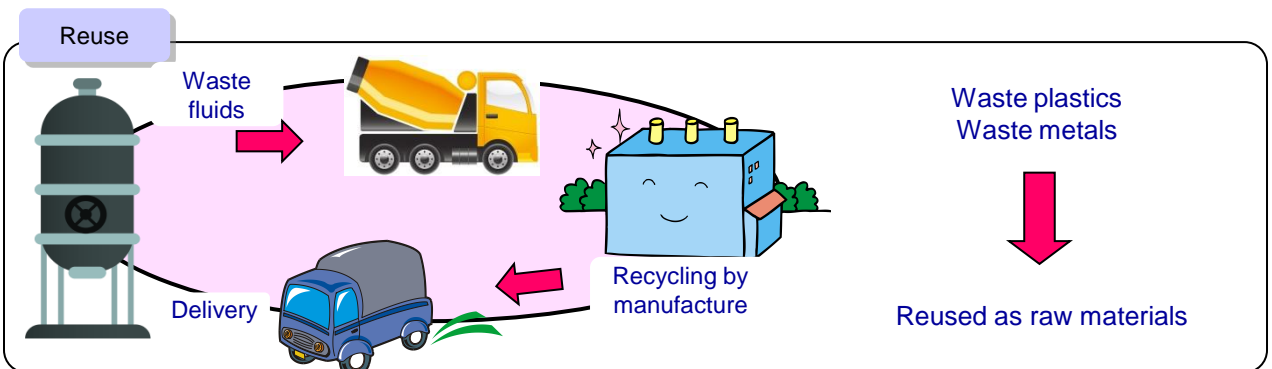
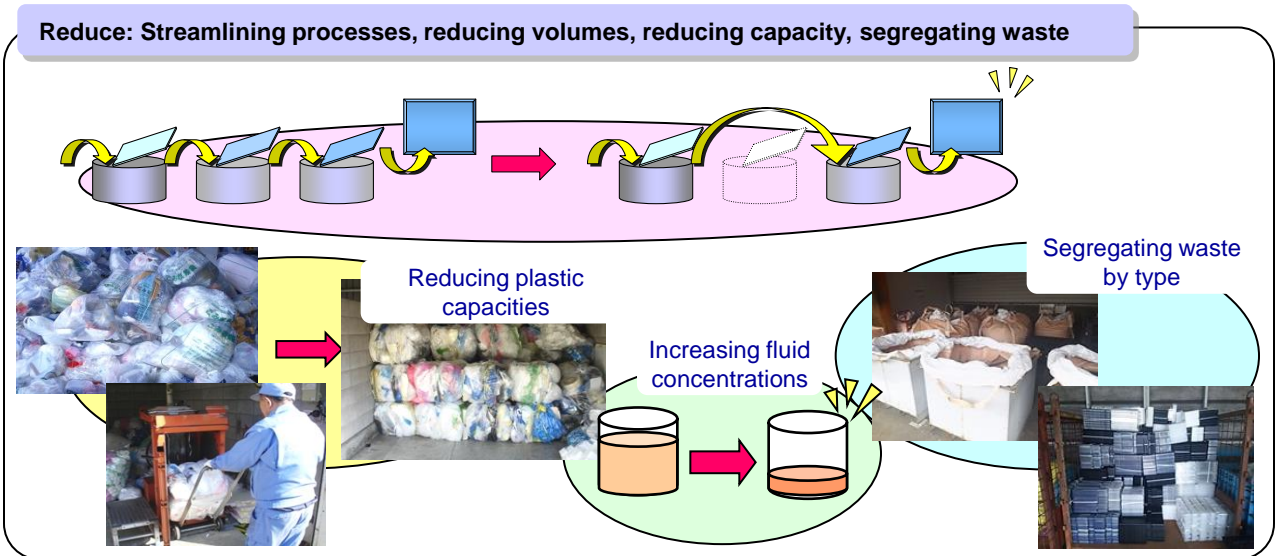

Legal Compliance

We confirm legal compliance in various ways, including internal environmental audits, and environmental compliance audits. No notable problems emerged in CY 2015.

Results of analysis and measurement at the Akita Plant (2015)

<Wastewater measurements in mg/l (excluding pH)>

Subject	Item	Value established jointly by the company and Akita city	Self-imposed standard value	Measured value (average)
Industrial wastewater	Hydrogen ion density (pH)	6.0 to 8.5	6.2 to 8.3	7.4
	Biochemical oxygen demand (BOD)	25	20	1.9
	Chemical oxygen demand (COD)	25	20	3.8
	Suspended substances (SS)	30	15	1.4
	Nonvolatile oil (normal hexane) content	10	1	< 1
	Chrome content	1	0.05	< 0.05
	Hexavalent chromium compounds	0.1	0.05	< 0.05
	Fluorine content	8	6	1.7
	Phosphor content	To be measured	4	0.06
	Nitrogen content	To be measured	60	8.3

<Soot and smoke measurements>

Subject	Item	Value established jointly by the company and Akita city	Self-imposed standard value	Measured value (average)
Cogeneration	Sulfur oxide (SOx)	K = 5	K = 0.5	K = 0.12
	Nitrogen oxide (NOx)	130 ppm	120 ppm	73 ppm
	Soot particles	0.1 g/m ³ N	0.015 g/m ³ N	< 0.02 g/m ³ N
Once-through boiler	Sulfur oxide (SOx)	K = 5	K = 0.5	K < 0.1
	Nitrogen oxide (NOx)	150 ppm	120 ppm	40 ppm
	Soot particles	0.15 g/m ³ N	0.12 g/m ³ N	< 0.01 g/m ³ N
Smoke-tube boiler	Sulfur oxide (SOx)	K = 5	K = 0.5	K < 0.1
	Nitrogen oxide (NOx)	150 ppm	120 ppm	80 ppm
	Soot particles	0.15 g/m ³ N	0.12 g/m ³ N	< 0.01 g/m ³ N

<Exhaust gas measurements>

Subject	Item	Value established jointly by the company and Akita city	Self-imposed standard value	Measured value (average)
Acid/organic exhaust gas cleaning tower	Hydrogen chloride	To be measured	10 mg/m ³ N	0.33 mg/m ³ N
	Hydrogen fluoride	To be measured	10 mg/m ³ N	0.25 mg/m ³ N
	Isopropyl alcohol	To be measured	450 ppm	0.27 ppm
	Ammonia	To be measured	3 mg/m ³ N	< 0.05 mg/m ³ N
Acid exhaust gas cleaning tower	Hydrogen chloride	To be measured	10 mg/m ³ N	0.19 mg/m ³ N
	Hydrogen fluoride	To be measured	10 mg/m ³ N	< 0.23 mg/m ³ N
	Ammonia	To be measured	3 mg/m ³ N	< 0.05 mg/m ³ N
Separation exhaust gas cleaning tower	Isopropyl alcohol	To be measured	450 ppm	20 ppm

Risk Management

In-house facilities are inspected and swift countermeasures taken to prevent accidents. These activities incorporate information shared on cases arising common plant accidents across Japan.

We patrol facilities involved in environment activities and undertake periodic drills to ensure appropriate response to chemical leaks and other incidents. A certification system for operators based on certain standards has been established for firms involved in supplying or transporting chemicals or collecting or transporting waste fluids. Overall schedules are meticulously confirmed and comprehensive safety warnings issued.

Before using any new equipment or chemical substances, we undertake advance assessments and development procedures to closely examine aspects such as the potential impact of chemical substances on the environment, safety, and products.

Drills in responding to environmental incidents such as chemical or gas leaks



2016 Environmental Activity Targets

Based on inputs and the results of activities in the previous year, our CY 2016 activities will have the following targets:

Items	Targets
Maintaining a 100% green procurement rate	100%
Maintaining 100% compliance with RoHS	100%
Reduction in carbon-dioxide emissions (from energy)	126.0 kg-CO ₂ /m ² or less*
Reduction of chemical substances	6.7 kg/m ² or less*
Reduction in Waste emissions	2.9 kg/m ² or less*

* A method of calculating the intensity has been changed from the previous years.



NLT Technologies, Ltd.

NLT Technologies, Ltd.

[HEAD OFFICE]

1753, SHIMONUMABE, NAKAHARA, KAWASAKI, KANAGAWA 211-8666, JAPAN

Contact: Development Division

TEL: +81-44-435-1666 (main switchboard)

FAX: +81-44-435-1927

[AKITA PLANT]

3-1-1, SHIMOTSUTSUMI, GOSHONO, AKITA 010-1412, JAPAN

Information on our environmental initiatives is also available on the Internet:
<http://www.nlt-technologies.co.jp>

Thank you for taking part in this survey.

Return to: Development Division, NLT Technologies, Ltd.
Fax: +81-44-435-1927

Please answer the following questions concerning your reactions to and impressions of the NLT Technologies, Ltd. Annual Environmental Report 2016 Edition.

Q1. Did you find the Annual Environmental Report clear and easy to understand?

- Easy to understand Average Hard to understand

Q2. How comprehensive was the coverage of the Annual Environmental Report?

- Full Average Insufficient

Q3. Did you find any of the subjects of this year's report particularly interesting? (Chose all answers that apply.)

- Message from the President Company Overview Map of NLT Technologies Business Sites
 Main Products Environmental Policy Environmental Management Organizational Structure
 Environmental Management System 2015 Results Environmentally Friendly Products
 Chemical Substances Contained in Products System Environmental Impact Mass Balance
 Preventing Global Warming (Promoting Energy Conservation) Controlling Chemical Substances
 Waste Control Legal Compliance Risk Management
 2016 Targets

Q4. Can you describe your relationship to the company and your perspective as a reader of this report?

- Active in business transactions with NLT Technologies Product user
 Government, administrative body Environmental NGO or NPO staff
 Corporate environmental staff Media Student or educational institution affiliate
 Other ()

Q5. How did you first learn about this Annual Environmental Report?

- NLT Technologies website Seminar, trade show Newspaper, magazine
 Other ()

Q6. Please provide any comments below on the Annual Environmental Report overall or on NLT Technologies' initiatives.

Name		Gender	M / F
Address			
Contact information	TEL	FAX	
	e-mail		
Occupation (name of employer, school, etc.)			

★ Please return this questionnaire after reviewing and consenting to the Privacy Policy.
(<http://www.nlt-technologies.co.jp>)

Thank you for your cooperation.